

# UM4BG12

**ISUZU**

ISUZU MARINE ENGINE INC.



# UM4BG1Z

## DIMENSIONS (mm)

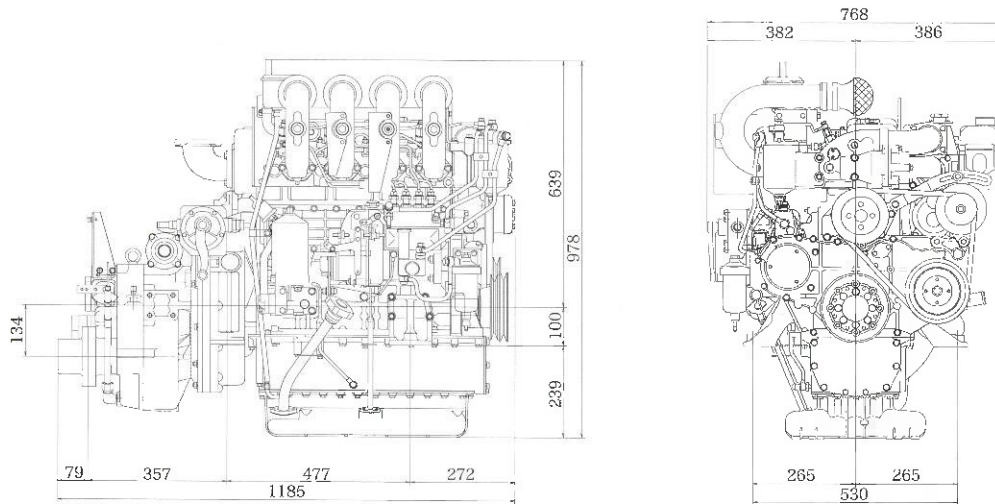

## PERFORMANCE CURVES

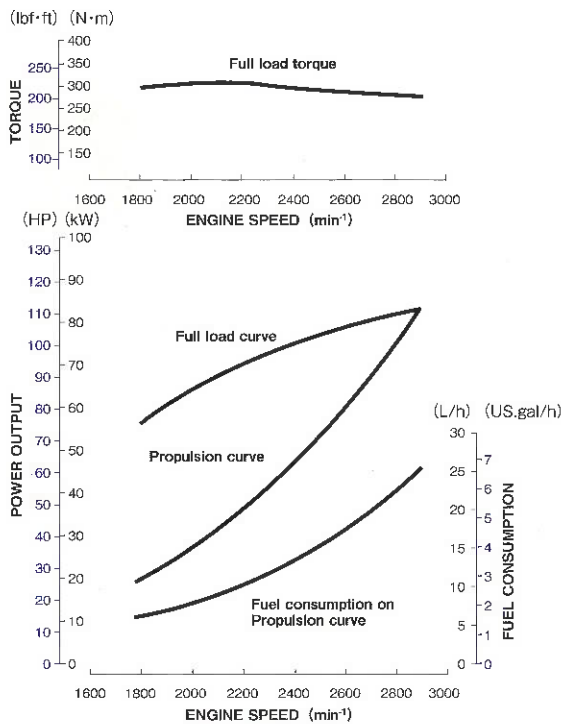

## ENGINE SPECIFICATIONS

|                                       |   |   |
|---------------------------------------|---|---|
| Configuration                         | 4-cylinder, vertical in-line, 4-cycle diesel engine             |   |
| Bore x Stroke                         | mm (in)   | 105 x 125 (4.13 x 4.92)                       |
| Displacement                          | Lit. (cid)  | 4.329 (264)                                   |
| Rated output                          | kW(PS)/min <sup>-1</sup>  | Medium duty 81 (110) / 2900                   |
| Application                           | Commercial use  |   |
| Governor type                         | Mechanical  |   |
| Combustion type                       | Direct injection  |   |
| Aspiration                            | Natural aspiration  |   |
| Engine weight                         | kg (lb)   | Engine 436 (961)<br>with MGN30A 560 (1,235)   |
| Fuel used                             | Diesel fuel   |   |
| Starter                               | V-kW  | 24 - 4.5                                      |
| Alternator                            | V-A   | 24 - 30                                       |
| Lubrication method                    | Full flow pressure circulation                                  |   |
| Cooling method                        | Freshwater, full flow pressure circulation (Seawater, indirect) |   |
| Heat exchanger (seawater circulation) | Multi-tube type (freshwater → seawater)                         |   |
| Intercooler                           | Multi-tube type (seawater circulation)                          |   |
| Rotation direction                    | Crankshaft  | Right (clockwise) viewed from front of engine |
|                                       | Propeller shaft   | Right (clockwise) viewed from stern           |
| Idling speed                          | min <sup>-1</sup>   | 500~550                                       |
| Marine gear                           | Marine Gear Model   | MGN30A  |
|                                       | Clutch type   | Wet, Multi-plate hydraulic type               |
|                                       | Reverse type  | Constant-mesh type gear                       |
|                                       | Reduction ratio   | 2.04, 2.52, 3.05, 3.44                        |

Specifications subject to change without notice

## ACCESSORIES

### Standard.....

- Installation kit
- Kingston valve
- Battery relay
- Extension harness (3m)
- Seawater pump impeller \*
- Bilge pump
- Control head
- Instrument panel
- Oil drain pump
- Blow-by pipe
- Tool kit
- Owner's manual

\* spare parts

### Option.....

- Extension harness (3m)
- Control cable (4m,6m,10m,12m)
- Stop cable (4m,6m,8m)

## ISUZU MARINE ENGINE INC.

<http://www.isuzumarine.co.jp>

